

IN-VEHICLE REPAIR

Engine Front Cover

Material

Item	Specification
Metal Surface Cleaner ZC-21	WSE-M5B392-A
Silicone Gasket and Sealant F7AZ-19554-EA or equivalent	WSE-M4G323-A4
SAE 5W-20 Premium Synthetic Blend Motor Oil XO-5W20-QSP or equivalent	WSS-M2C930-A

Removal

1. With the vehicle in NEUTRAL, position it on a hoist. For additional information, refer to Section 100-02.
2. Release the fuel system pressure. For additional information, refer to Section 310-00A.
3. Disconnect the battery ground cable. For additional information, refer to Section 414-01.
4. Remove both valve covers. For additional information, refer to Valve Cover RH or Valve Cover LH in this section.
5. Remove the coolant pump. For additional information, refer to Section 303-03.
6. Remove the bolts and position the power steering pump aside.

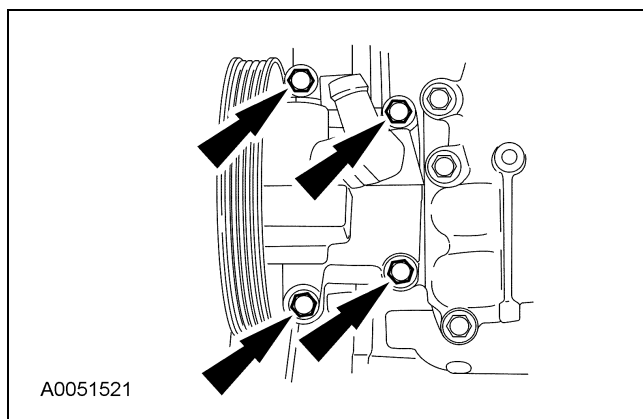

7. Remove the oil pan drain plug and drain the engine oil.

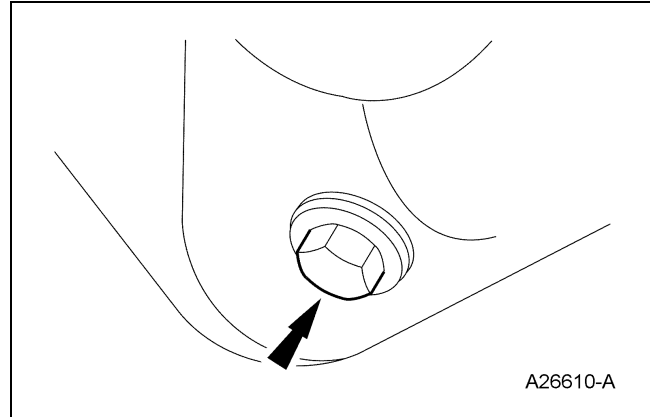

8. Remove the four bolts.

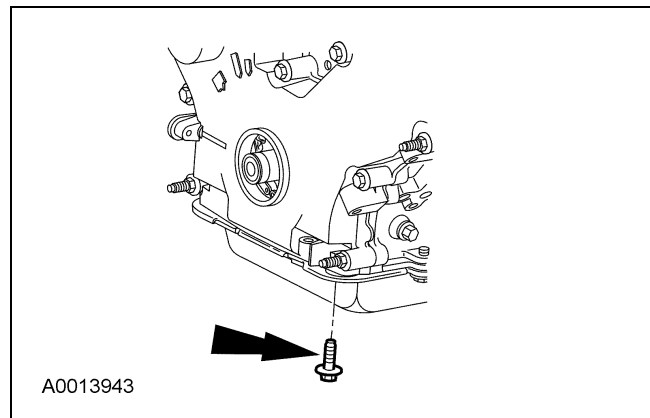

9. Remove the crankshaft front oil seal. For additional information, refer to Crankshaft Front Oil Seal in this section.

10. Remove the bolt and the belt idler pulley.

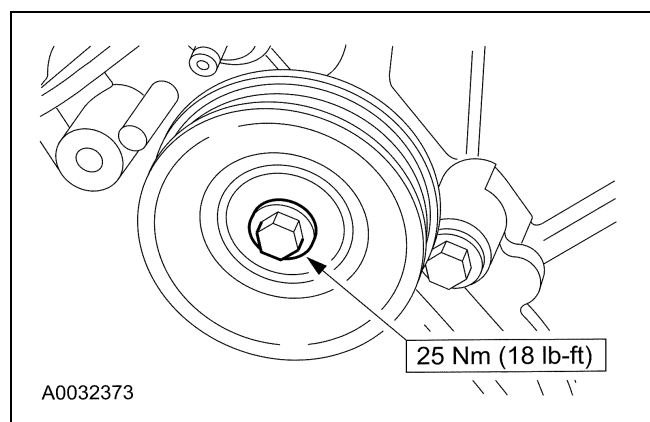

IN-VEHICLE REPAIR (Continued)

11. Remove the bolts and the stud bolts in the sequence shown.

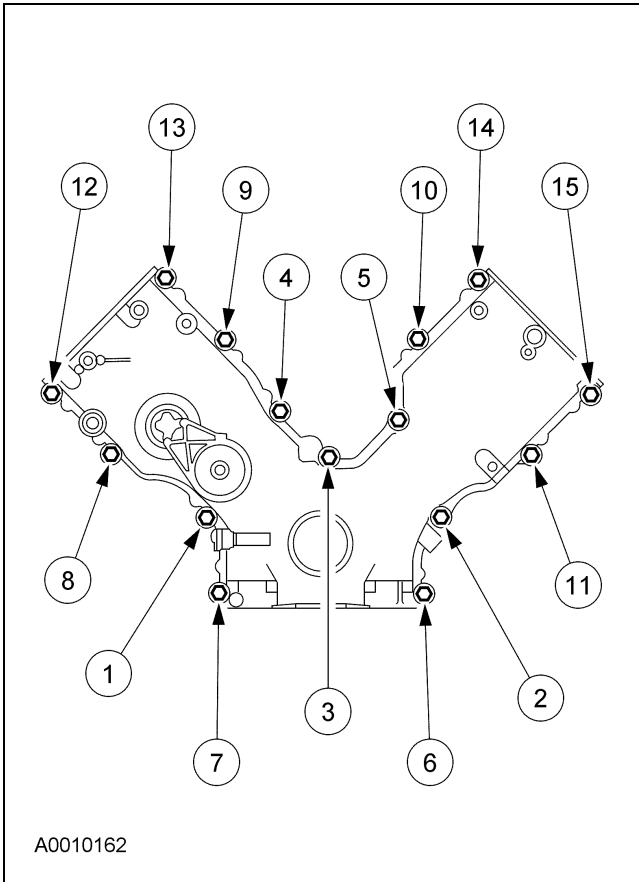

12. **⚠ CAUTION: Do not use metal scrapers, wire brushes, power abrasive discs or other abrasive means to clean the sealing surface. These tools cause scratches and gouges that make leak paths. Use a plastic scraping tool to remove all traces of the gasket material.** Remove the engine front cover from the front cover-to-cylinder block dowel.

- Clean the gasket surfaces with a plastic scraping tool and metal surface cleaner.

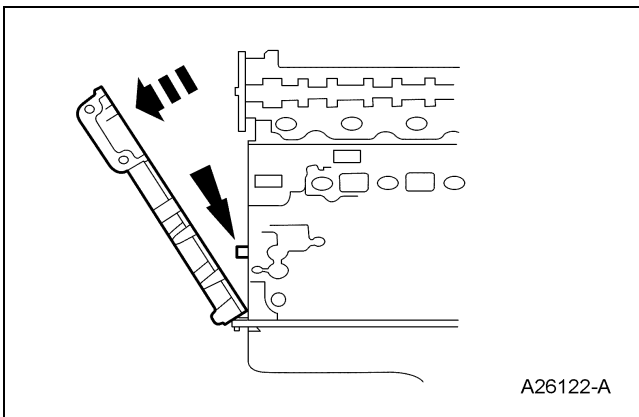
**Installation**

1. **NOTE:** If the engine front cover is not secured within four minutes, the sealant must be removed and the sealing area cleaned with metal surface cleaner. Allow to dry until there is no sign of wetness, or for four minutes, whichever is longer. Failure to follow this procedure can cause future oil leakage.

Apply sealant along the cylinder head-to-block surface and the oil pan-to-cylinder block surface.

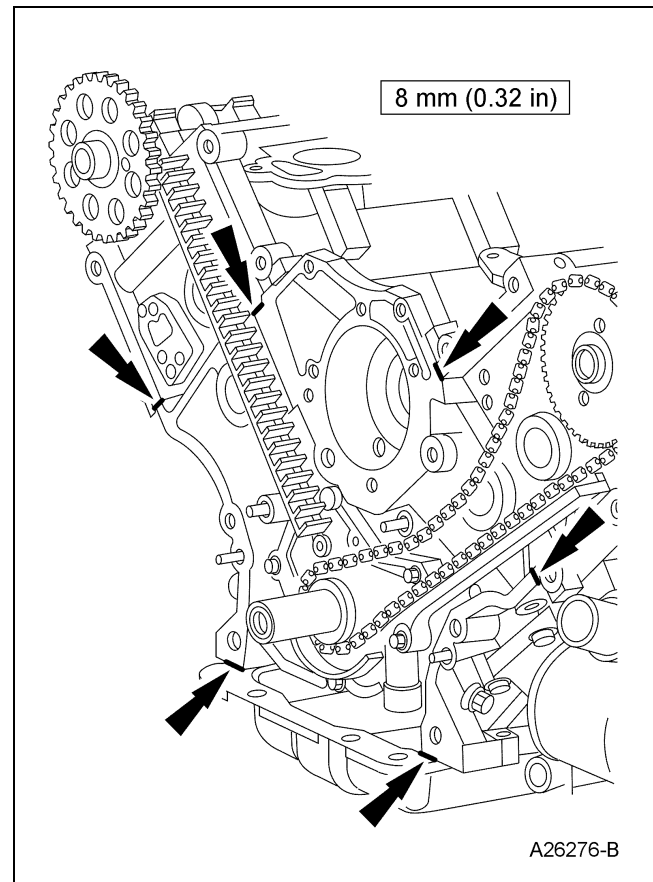

IN-VEHICLE REPAIR (Continued)

- Install the engine front cover on the front cover-to-cylinder block dowel and loosely install the bolts.

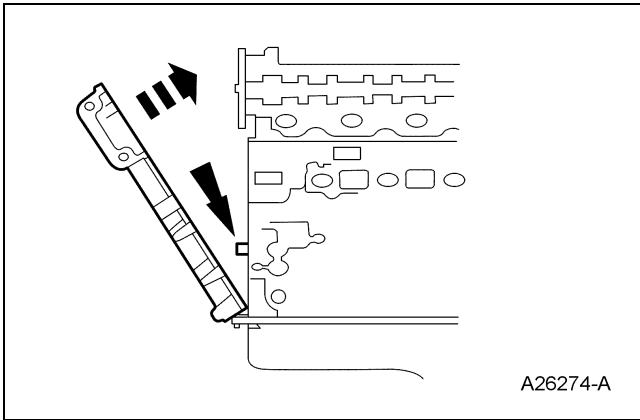

- Tighten the front cover bolts and stud bolts in sequence in two stages.

Item	Part Number	Description
1	N806177	Bolt, hex flange head pilot, M8 x 1.25 x 53
2	N806177	Bolt, hex flange head pilot, M8 x 1.25 x 53
3	N806177	Bolt, hex flange head pilot, M8 x 1.25 x 53
4	N806177	Bolt, hex flange head pilot, M8 x 1.25 x 53
5	N806177	Bolt, hex flange head pilot, M8 x 1.25 x 53
6	N806177	Bolt, hex-head pilot, M10 x 1.5 x 103.1
7	N808529	Stud, hex-head pilot, M10 x 1.5 x 103.1
8	N808142	Screw and washer, hex-pilot, M10 x 1.5 x 57.5
9	N808142	Screw and washer, hex pilot, M10 x 1.5 x 57.5
10	N808142	Screw and washer, hex pilot, M10 x 1.5 x 57.5
11	N808140	Stud and washer, hex-head pilot, M10 x 1.5 x M8 x 1.25 x 109.6

Item	Part Number	Description
12	N808140	Stud and washer, hex-head pilot, M10 x 1.5 x M8 x 1.25 x 109.6
13	N808140	Stud and washer, hex-head pilot, M10 x 1.5 x M8 x 1.25 x 109.6
14	N808140	Stud and washer, hex-head pilot, M10 x 1.5 x M8 x 1.25 x 109.6
15	N808140	Stud and washer, hex-head pilot, M10 x 1.5 x M8 x 1.25 x 109.6

- Stage 1: Tighten fasteners 1 through 7 to 25 Nm (18 lb-ft).
- Stage 2: Tighten fasteners 6 through 15 to 48 Nm (35 lb-ft).

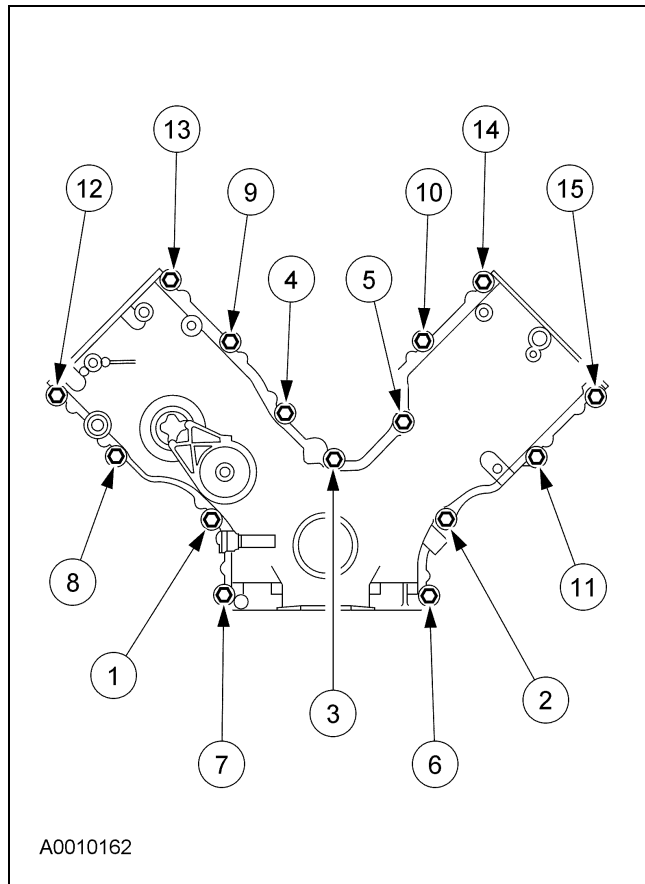

IN-VEHICLE REPAIR (Continued)

4. Position the belt idler pulley and install the bolt.

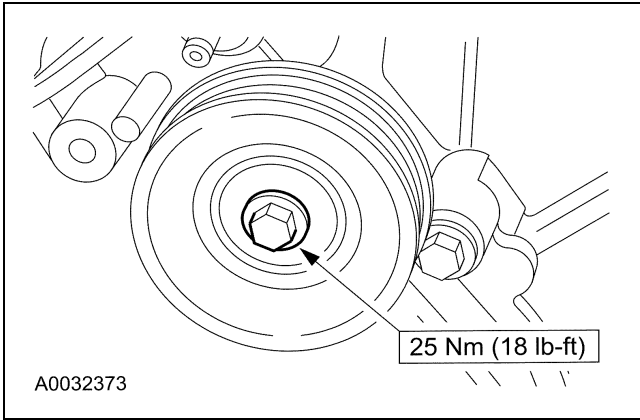

5. Install a new crankshaft front oil seal. For additional information, refer to Crankshaft Front Oil Seal in this section.

6. Loosely install the front oil pan bolts.

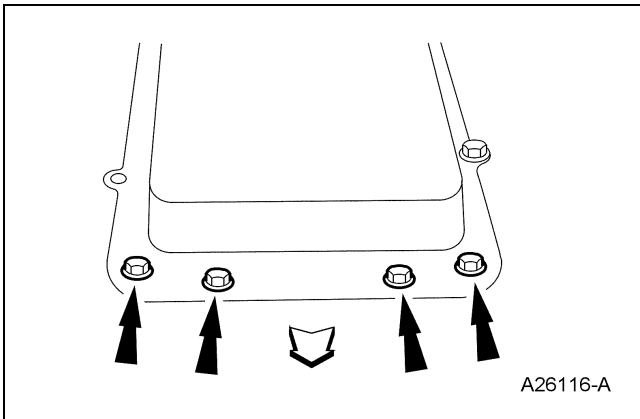

7. **NOTE:** Make sure to tighten the bolts in two stages.

Tighten the bolts in two stages.

- Stage 1: Tighten to 20 Nm (15 lb-ft).
- Stage 2: Tighten an additional 60 degrees.

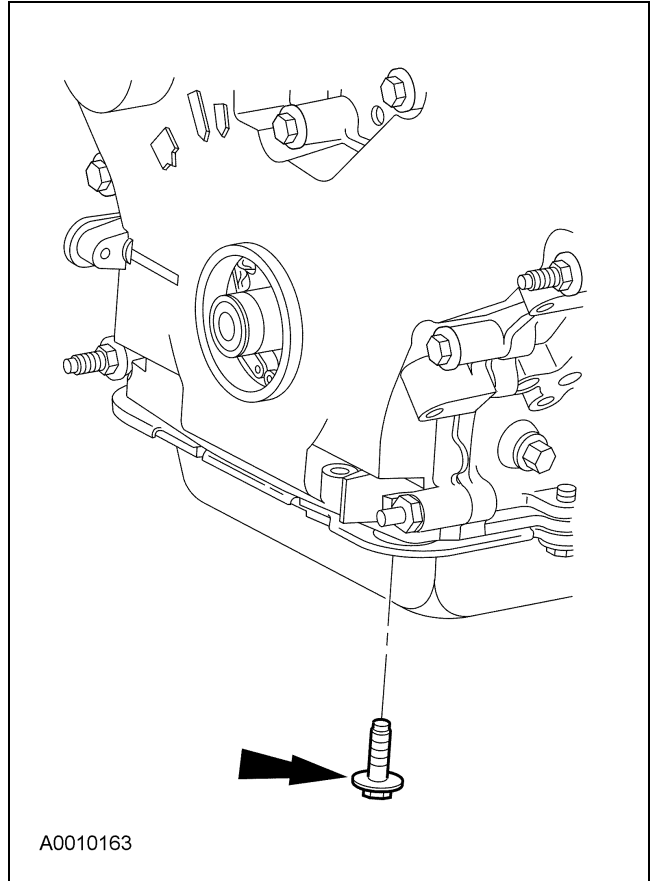

8. **NOTE:** The front lower hole in the power steering pump is not used.

Position the power steering pump and install the bolts.

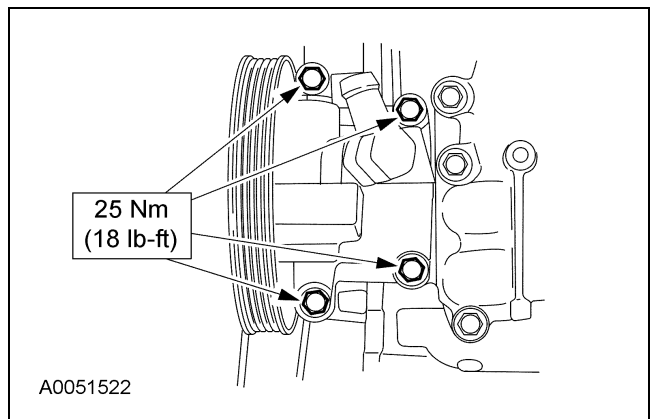

IN-VEHICLE REPAIR (Continued)

9. Install the oil pan drain plug.

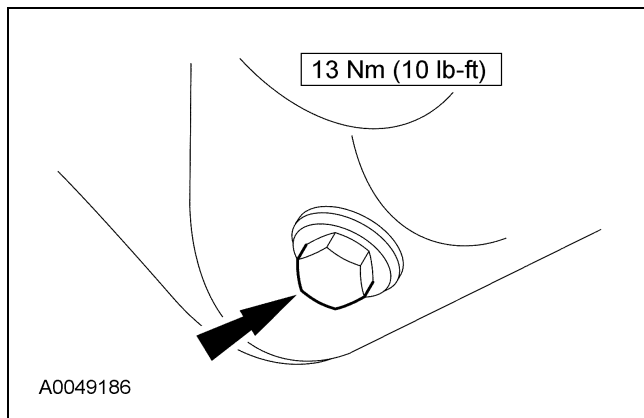

10. Install the valve covers. For additional information, refer to Valve Cover RH or Valve Cover LH in this section.
11. Install the coolant pump. For additional information, refer to Section 303-03.
12. Connect the battery ground cable. For additional information, refer to Section 414-01.
13. Fill the engine with oil.